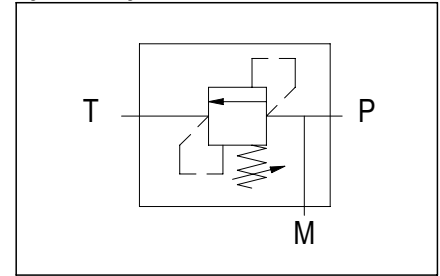
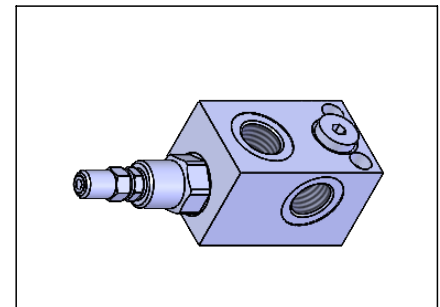
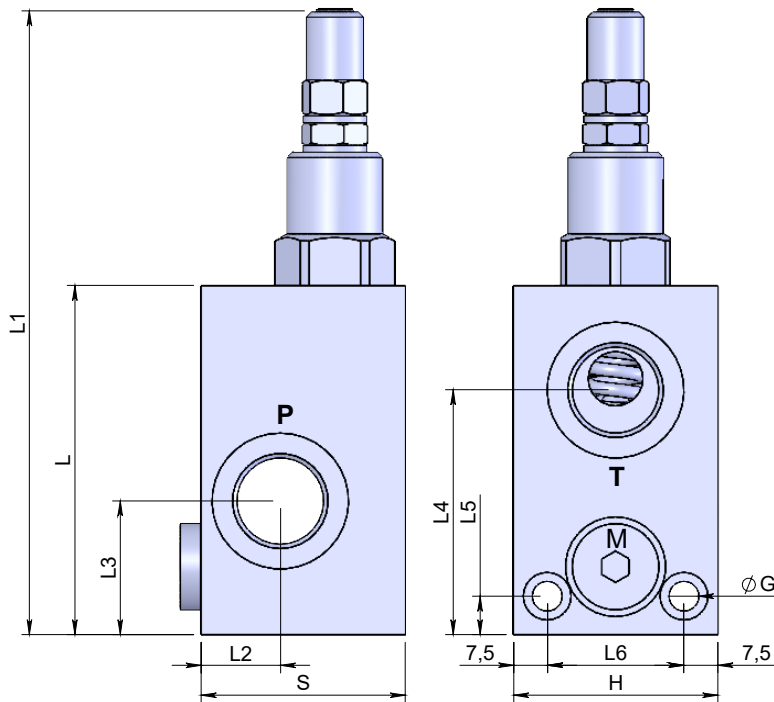
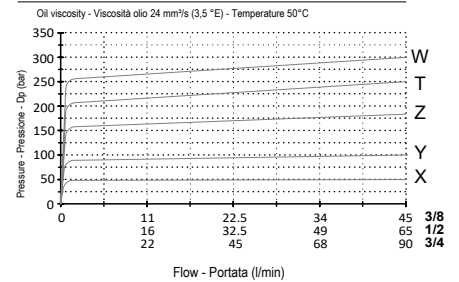

**Relief valve in manifold with manometer port  
Valvola di massima pressione in collettore con attacco manometro**

**Specifications / Specifiche**

Fluid viscosity:	Viscosità Fluido :	ISO 3448
Filtration:	Classe di contaminazione:	ISO 4406
Fluid temperature:	Temperatura fluido:	-20°C +90°C
Ambient temperature:	Temperatura ambiente:	-20°C +50°C
Max. operating pressure:	Pressione di lavoro max :	350 Bar
Standard seals:	Guarnizioni standard:	NBR 70 Shore A
Manifold material:	Materiale collettore:	Zinc plated steel

**Hydraulic symbol / Simbolo idraulico**

**Dimensions / Dimensioni (mm)**

**Performance / Prestazioni**

**How to order / Come ordinare**
**10-L-00-C02-3-R-\*\*-\***

R= Screw with steel cap (Std) Adjustment  
N= Tamper resistant cap Regolazione  
O= Handknob and locknut

03 = 3/8 BSPP Ports size  
04 = 1/2 BSPP Dimensione attacchi  
05 = 3/4 BSPP

Std setting at 5 l/min  
X = 10-50 bar 30 bar  
Y = 20-100 bar 70 bar  
Z = 10-180 bar (Std) 90 bar  
T = 50-250 bar 130 bar  
W = 80-300 bar 150 bar

Setting range  
Campo taratura

Standard code Codice standard	Thread/Filetto		M	L	L1	L2	L3	L4	L5	L6	G	H	S	Weight/Peso (kg)	Max. Flow Q max (l/min)
	P	T													
10L00C023R03Z	3/8	3/8	1/4	72	134	15	26	49.5	8.5	26	6.5	40	40	0.8	45
10L00C023R04Z	1/2	1/2	1/4	77	139	17.5	29.5	54	8.5	30	6.5	45	45	1.0	70
10L00C023R05Z	3/4	3/4	1/4	92	154	20	35	68	10	32	8.5	50	50	1.5	90

\*On request versions: Please, contact our customer service.

\*Versioni su richiesta: Per cortesia contattare il ns. servizio clienti.