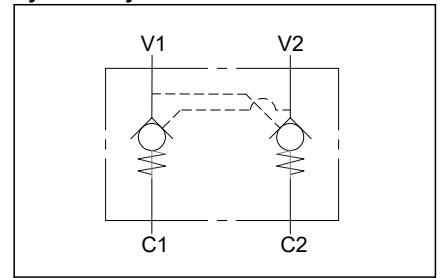
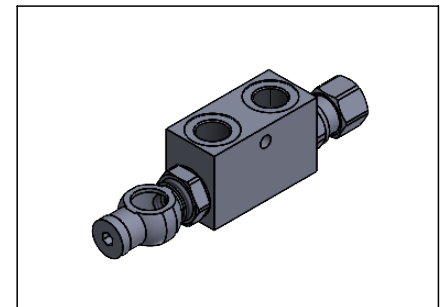
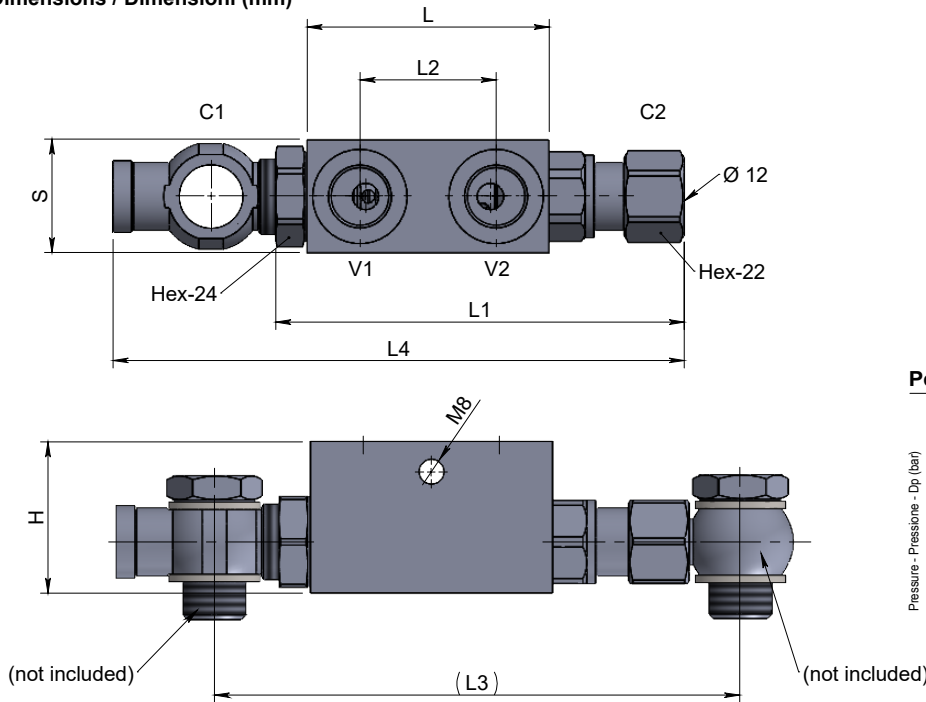
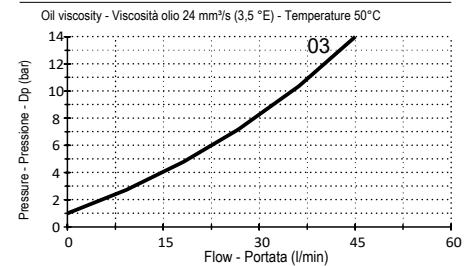

Dual pilot operated check valve with adjustable banjo union
Valvola di blocco pilotata doppio effetto con raccordo ad occhio orientabile

Specifications / Specifiche

Fluid viscosity:	Viscosità Fluido :	ISO 3448
Filtration:	Classe di contaminazione:	ISO 4406
Fluid temperature:	Temperatura fluido:	-20°C +90°C
Ambient temperature:	Temperatura ambiente:	-20°C +50°C
Max. operating pressure:	Pressione di lavoro max :	350 Bar
External surfaces:	Superfici esterne:	Zinc plated/Zincate
Standard seals:	Guarnizioni standard:	NBR 70 Shore A

Hydraulic symbol / Simbolo idraulico

Dimensions / Dimensioni (mm)

Performance / Prestazioni

How to order / Come ordinare
14-D-03-A00-3-*-03-*

 M=With OR Std.] OR on pilot piston
 N=Without OR] OR su pistone pilota

 Cracking pressure] Y = 3 bar (std)
 Pressione di apertura] X = 1 bar
] Z = 8 bar

Standard code Codice standard	Thread/Filetto		L	L1	L2	L3	L4	H	S	Weight/Peso (kg) Steel / Acciaio	Max. Flow Q max (l/min)	Pilot ratio Rapp. pil.
	V1-V2	C1-C2										
14D03A003M03Y	3/8	Ø12-3/8	64	106	36	(136)	(151)	40	30	0.9	30	5.5 : 1

*On request versions: Please, contact our customer service.

*Versioni su richiesta: Per cortesia contattare il ns. servizio clienti.