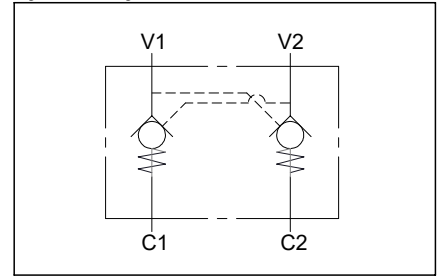
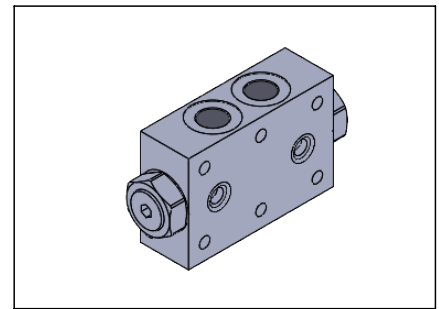
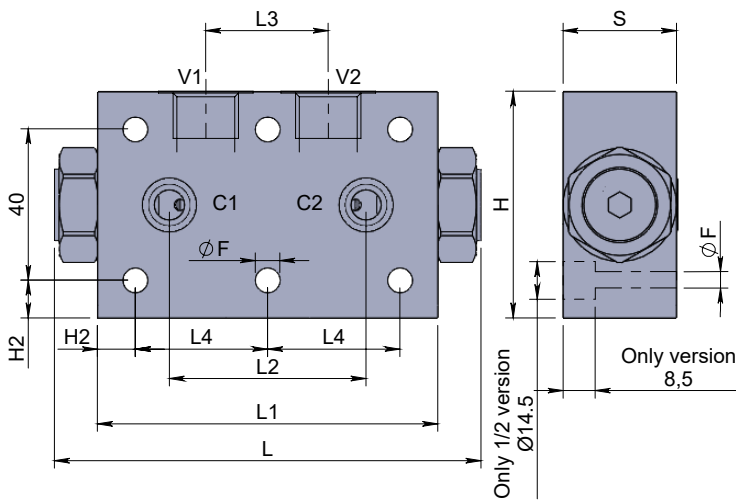
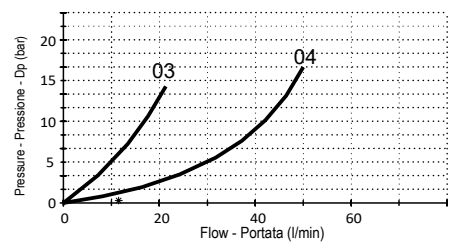

**Flangiabile dual pilot operated check valve
Valvola di blocco pilotata doppio effetto flangiabile**

Specifications / Specifiche

Fluid viscosity:	Viscosità Fluido :	ISO 3448
Filtration:	Classe di contaminazione:	ISO 4406
Fluid temperature:	Temperatura fluido:	-20°C +90°C
Ambient temperature:	Temperatura ambiente:	-20°C +50°C
Max. operating pressure:	Pressione di lavoro max :	350 Bar
External surfaces:	Superfici esterne:	Zinc plated/Zincate
Standard seals:	Guarnizioni standard:	NBR 70 Shore A

Hydraulic symbol / Simbolo idraulico

Dimensions / Dimensioni (mm)

Performance / Prestazioni

 Oil viscosity - Viscosità olio 24 mm²/s (3,5 °E) - Temperature 50°C

How to order / Come ordinare
14-M-06-B01-3-*-*-***

 3=Zinc plated steel Std.
For aluminium version contact
our customer service.

Material

Materiale

 Cracking pressure X = 1 bar
Pressione di apertura Y = 3 bar Std
Z = 8 bar

M=With OR Std. OR on pilot piston

N= Without OR OR su pistone pilota

 P-T Port size 03 = 3/8 BSPP
Dimensione attacchi P-T 04 = 1/2 BSPP

Standard code Codice standard	Thread/Filetto		L	L1	L2	L3	L4	H	S	H2	ØF	Weight/Peso (kg)	Max. Flow Q max (l/min)	Pilot ratio Rapp. pil.
	V1-V2	C1-C2												
14M06B013M03Y	3/8	Ø6	113	90	52	30	35	60	30	10	6.5	1.2	30	6.25 : 1
14M06B023M03Y	3/8	Ø6	113	90	62	32	35	60	35	10	6.5	1.4	30	6.25 : 1
14M06B013M04Y	1/2	Ø9	138	110	65	34	40	70	34	15	8.5	1.8	60	4 : 1

*On request versions: Please, contact our customer service.

*Versioni su richiesta: Per cortesia contattare il ns. servizio clienti.