

Dual pilot operated check valve DIN series

Valvola di blocco pilotata doppio effetto serie DIN

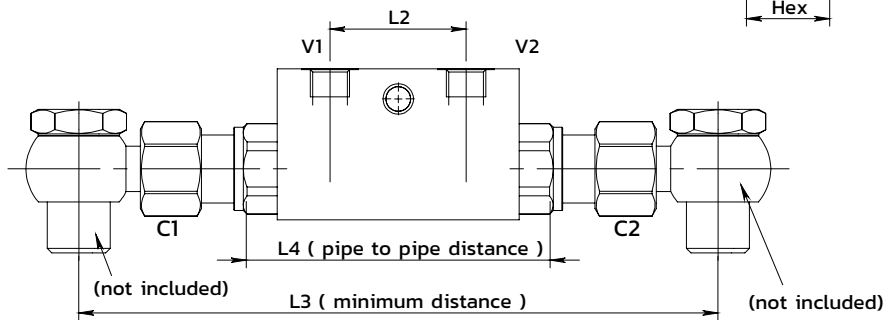
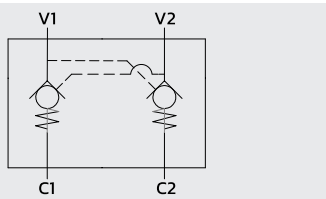
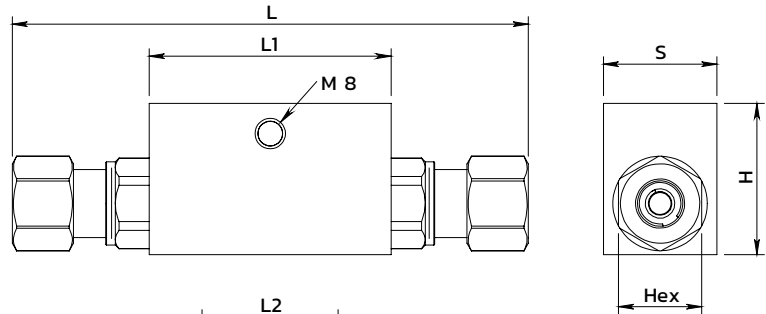
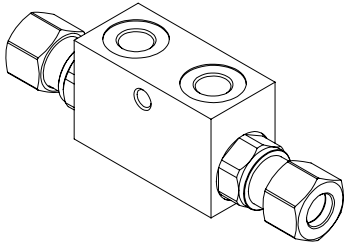

SPECIFICATIONS / SPECIFICHE

Fluid viscosity / Viscosità fluido	ISO 3448
Filtration / Classe di contaminazione	ISO 4406
Fluid temperature / Temperatura fluido	-20°C +90°C
Ambient temperature / Temperatura ambiente	-20°C +50°C
Max operating pressure / Pressione di lavoro max	350 bar
Standard seals / Guarnizioni standard	NBR 70 Shore A
Manifold material / Materiale collettore	Zinc plated steel

PERFORMANCE / PRESTAZIONI

Oil viscosity 24 mm²/s (35 °E) - Temperature 50°C

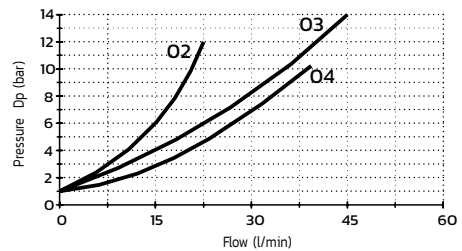

ORDERING CODE / CODICE ORDINAZIONE

14 N 02 A04 3 M ** *

OR on pilot piston	
M	With OR (Std)
N	Without OR

Ports size	
O2	1/4 BSPP
O3	3/8 BSPP
O4	1/2 BSPP

Cracking pressure	
Y	3 bar (Std)
X	1 bar
Z	8 bar

Standard code	Thread V1-V2 C1-C2	L	L1	L2	L3	L4	H	S	Hex	Weight kg Steel	Max Flow (l/m)	Pilot ratio
14N02A043M02Y	1/4 Ø12	130	64	36	160	80	40	30	22	0.69	20	5.5 :1
14N02A043M03Y	3/8 Ø12	130	64	36	160	80	40	30	22	0.67	30	5.5 :1
14N02A043M04Y	1/2 Ø15	164	90	45	196	104	45	35	27	1.10	50	5 : 1

* On request versions: Please, contact our customer service / Versioni su richiesta: Per cortesia contattare il ns. servizio clienti.